

400HFS-L Hi-Flow Thruster

Product Guide and Warranty



Hi-Flow Thruster Warranty

CrustCrawler has a strong commitment to the high quality production of its HI-FLOW THRUSTERS and to provide industry leading after-sales support for our customers. Every HI-FLOW THRUSTER (GOODS) is fully covered by a comprehensive warranty to the original owner (OWNER) against defects in materials or workmanship for a period of 1 month from the date of shipment, whether or not use starts from that date. All claims under this limited warranty shall be deemed waived unless received by CrustCrawler within 10 days of delivery if visibly damaged or defective, and, otherwise, within 30 days after the defect to which each claim relates is discovered. This is not an unconditional guarantee against all hazards or failures and the Limitations and Exclusions listed below apply.

THIS WARRANTY IS EXPRESSLY IN LIEU OF ANY OTHER WARRANTIES EXPRESSED OR IMPLIED, INCLUDING ANY IMPLIED WARRANTY OF MERCHANTABILITY OR FITNESS.

This warranty is extended to the original OWNER of the GOODS and is not transferable. This warranty is limited solely to the repair or replacement, at our factory, of the defective GOODS. CrustCrawler shall not be liable for any damage or harm, nor for any exemplary, special, punitive, consequential or incidental damages, including but not limited to any loss of revenue, profit or use resulting thereby. If a component is found to be defective during the period of this warranty, CrustCrawler reserves the right to repair or replace the defective component or to refund the original purchase price at its own discretion. In no event shall CrustCrawler be liable for more than the original purchase price of the defective GOODS.

Limitations and Exclusions

This limited warranty does not cover:

- Damage caused by improper use, improper maintenance, incorrect reassembly or accidental damage
- Items subject to normal wear including but not limited to surface finish, seals, motors, gear box and cables unless found to be defective in workmanship or materials
- Modification made to the HI-FLOW THRUSTER without prior authorization from CrustCrawler Inc
- Damage due to incorrect power connection as described in the User's Manual
- Damage or failure that is caused by acts of God, acts of war, or other such similar or dissimilar occurrences beyond CrustCrawler's control.

Shipping and Return Material Authorization (RMA) Forms

Immediately upon identifying a problem which you believe to be subject to this limited warranty, you must request warranty service by contacting CrustCrawler. All requests for warranty service must be authorized by CrustCrawler prior to return of the GOODS. You must first attempt to work with our technical support staff to help diagnose the problem. This may include performing routine diagnostic procedures. The technician can determine if the problem can be resolved over the telephone or if return for repair is required. Upon determining that the product may be defective under the terms of the limited warranty, and that return to the repair facility is required, CrustCrawler will issue an RMA number which you must complete and return to CrustCrawler. Upon receipt of the RMA number, the GOODS can then be shipped to CrustCrawler for evaluation.

Do not return the GOODS to CrustCrawler prior to the receipt of the RMA number. The GOODS must be shipped in their original shipping containers and packing material or otherwise adequately packed for shipment, and the RMA number must appear clearly on the outside of the package. If the product is damaged during shipment or received in inadequate packaging, this warranty may not apply.

For warranty shipping, the OWNER is responsible for shipment of all GOODS to CrustCrawler and CrustCrawler will cover the costs of return shipment of GOODS to the OWNER up to \$90.00 USD maximum.

In all cases the OWNER is liable for damage to the GOODS that may occur during shipment and should consider insuring the shipment both to and from CrustCrawler.

CrustCrawler “High Flow 400HFS-L” Series AUV/UROV Thruster Technical Specifications

CrustCrawler’s “High Flow” AUV / UROV 400HFS-L thrusters were designed to be extremely powerful and customizable for any number of our customers unique UROV / ROV requirements. No other thruster on the market has the programmable flexibility to set specific operating parameters for different environmental conditions than the CrustCrawler “High Flow” series. Machined from top of the line materials the Hi-Flow 400HFS-L thrusters are engineered for powerful thrust capability in a small package.

Motor Specifications

- Motor Type – High efficiency brushless
- Weight – 185g. (6.5oz)
- Max Power – 400W (130W max for the thruster)
- Gear Ratio – 4.28:1
- Shaft Diameter – 5.0mm (.1969”)
- Maximum Case Temperature – 100C (212F)
- Operating Voltage – 12 to 50 volts
- Operates in forward and reverse thrust

Connector Specifications

- Depth Rating – 300 ft.
- 3 wire

Thruster Housing / End Caps

- T- 6 Aluminum

Thruster Seal

- Motor - Flexible, polyurethane encapsulating compound
- Shaft Seal – Fluoroloy Lip Seal followed by encapsulating grease gallery

Thruster Weight

- Weight in air - 1 pound (.453kg)
- Weight in Water – 9 ounces (255 grams)

Thruster Length

- 6.25” (15.87cm)

Finish

- Black / Red Type II Hard Anodized Finish

Propeller

- Size – 2.36” (60mm) - 4 blade
- Material – Solid Brass
- Propeller Adapter – Machined aluminum / Anodized Type II Black

Kort Nozzle Adaptor

- Material – .090 Aluminum
- Offset - 120 degrees

Thrust Rating (130W max)

- 15 pounds + (6.79kg) (approx. 130W max)
- 12 Volts – 8 pounds of thrust max
- 24 Volts – 15 pounds of thrust max
- 50 Volts - 15 pounds of thrust max

- **Note # 1** - At no time shall the thrust rating of 15lbs be exceeded or damage to the thruster may occur.

- **Note# 2** - Never Exceed the 130W (voltage X current) or damage to the motor will occur. **Always monitor your current consumption based on 12, 25 and 50 volt usage to ensure you do not exceed 130W.**

Thrust vs. Current Rating at 24v (130W max)

Thrust (kg)	Thrust (pounds)	Current (Amps)
.453	1	.14
.906	2	.40
1.36	3	.60
1.81	4	.81
2.26	5	1.16
2.72	6	1.46
3.17	7	1.94
3.62	8	2.30
4.08	9	2.70
4.53	10	3.15
4.98	11	3.56
5.44	12	3.89
5.89	13	4.35
6.34	14	4.69
6.79	15	5.26

Note: The current rating for a moving UROV can be as much as 20% – 30% lower than the current rating indicated above depending on UROV size and weight.

A Note about Throttle Settings and Maximum Power of the Thruster

Whatever throttle you choose to use (computer, joystick etc.) with the 400HFS-L Hi-flow Thruster it is important to note the following:

1. Once you complete the calibration routine of the throttle device you are using with the Hydra / Phoenix ESC's it is important to note that your full throttle settings **DO NOT DIRECTLY** relate to the maximum power rating of the thruster!
2. In order to determine the maximum physical setting that you can move your throttle to without exceeding the thrust rating of the 400HFS-L thruster of 15 pounds, you will have to monitor either the thrusters thrust rating so that it does not exceed 15 lbs. of thrust and/or ensure it does not exceed about 130W of power at 24volts (as an example)

Note: Refer to the Current / vs. Thrust rating chart on page 5.

- Failure to do so will result in thermal damage to the 400HFS-L thruster motor!

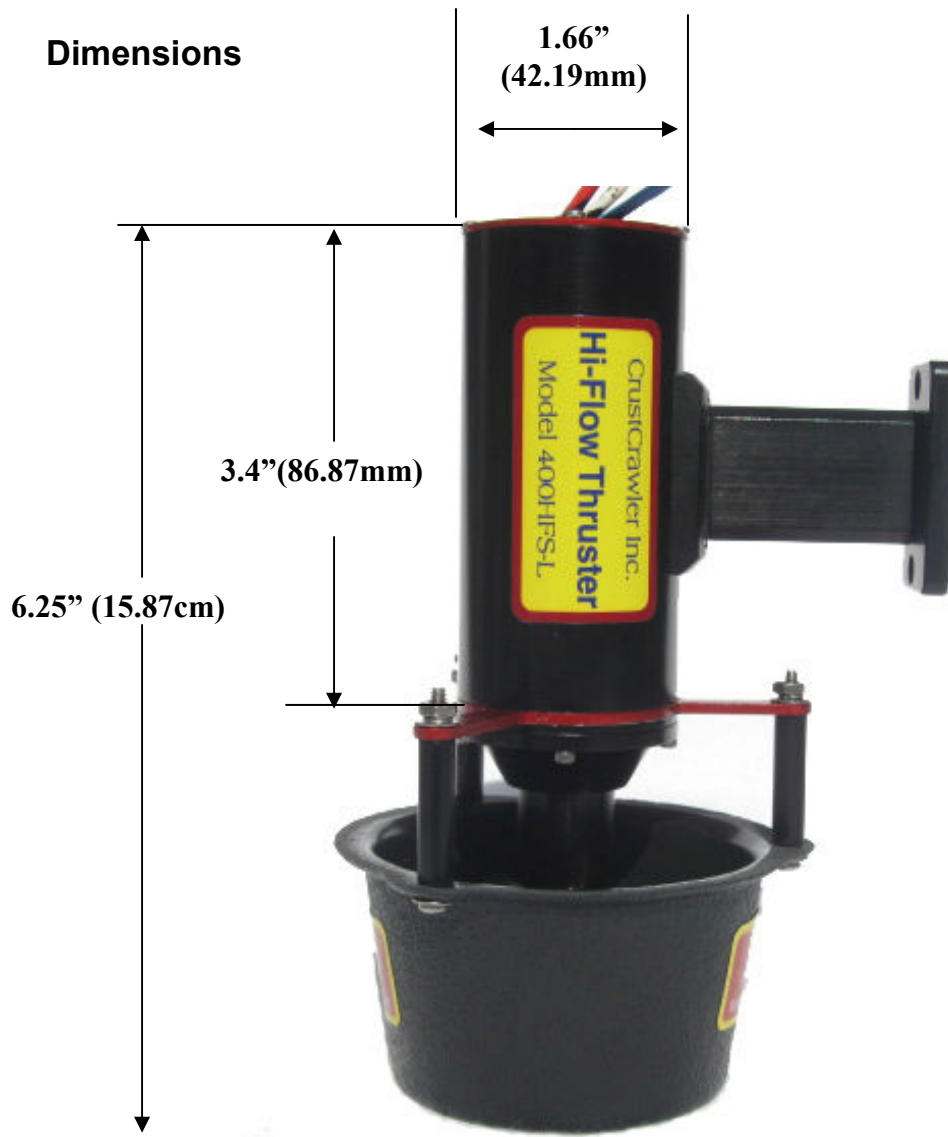

- Kort Nozzle Inlet – 2.80" (71mm)
- Kort Nozzle Outlet – 2.44" (62mm)

Safety

- Always unplug the Hi-Flow thruster before handling the propeller in any way.
- Always practice safe electrical handling and safety practices when working around water.

Break-In Period

The Hi-Flow thruster can be run at any speed right out of the box fully submersed. However, do not run the Hi-Flow thruster out of the water at high speeds for longer than 30 to 60 seconds or overheating and possible damage can occur.

Thruster Control

Any brushless motor control software / hardware can be used to operate the Hi-Flow thrusters. CrustCrawler offers a specifically engineered Hydra / Phoenix ESC controller from Castel Creations. We have also have a suggested control diagram in this manual for thruster control as an option. However, thruster control is up to you our customer.

Connecting the Castle Creation Electronic Speed Controller (ESC) to the Hi-Flow Thruster

CrustCrawler has engineered a special UV resistant, potted and completely waterproof housing for the Castle Creations Hydra / Phoenix ESC (brushless electronic speed controller). This design allows you to bolt the ESC directly to your UROV. All of the Hi-Flow thrusters have been internally wired the same way, so the diagrams shown on the subsequent pages will apply to any series of Hi-Flow thruster.



Figure 1 - ESC Controller

- The Hydra / Phoenix ESC uses Pulse Width Modulation (PWM) for brushless motor control (full forward - 2ms square wave, full reverse – 1ms square wave, neutral 1.5 ms square wave).. Customization of throttle and brake curves along with forward and reverse characteristics can be programmed using the Castle Creations Castle Link USB programming kit.
- Each thruster will require (1) ESC. Do not attempt to connect and control (2) thrusters with (1) ESC.
- Any brushless speed controller with a rating of at least 20 amps with reverse capability can be used with the 400HFS-L Thruster.

Note: Ensure that you provide a solid, soldered connection when connecting the ESC to the thruster. Also, use shrink tubing or any other type of sealant to ensure the soldered connection is sealed and waterproof (“Liquid Tape” is an excellent, fast drying sealant that can be purchased at most hardware stores). Always use wires that are equal to or greater in thickness than the wires on the thruster and ESC!

- A Parallax Servo Controller (PSC – optional) can be used to attach each Hydra / Phoenix ESC to a specified channel to control each thruster independently with either software, joystick control or both. A single PSC can control up to 16 thrusters.



Figure 2 - Parallax Servo Controller

- For more detailed information on the operating parameters and wiring characteristics of the Castle Creations Hydra / Phoenix ESC, be sure to read the enclosed documentation that came with your ESC.

Power / Signal Connection

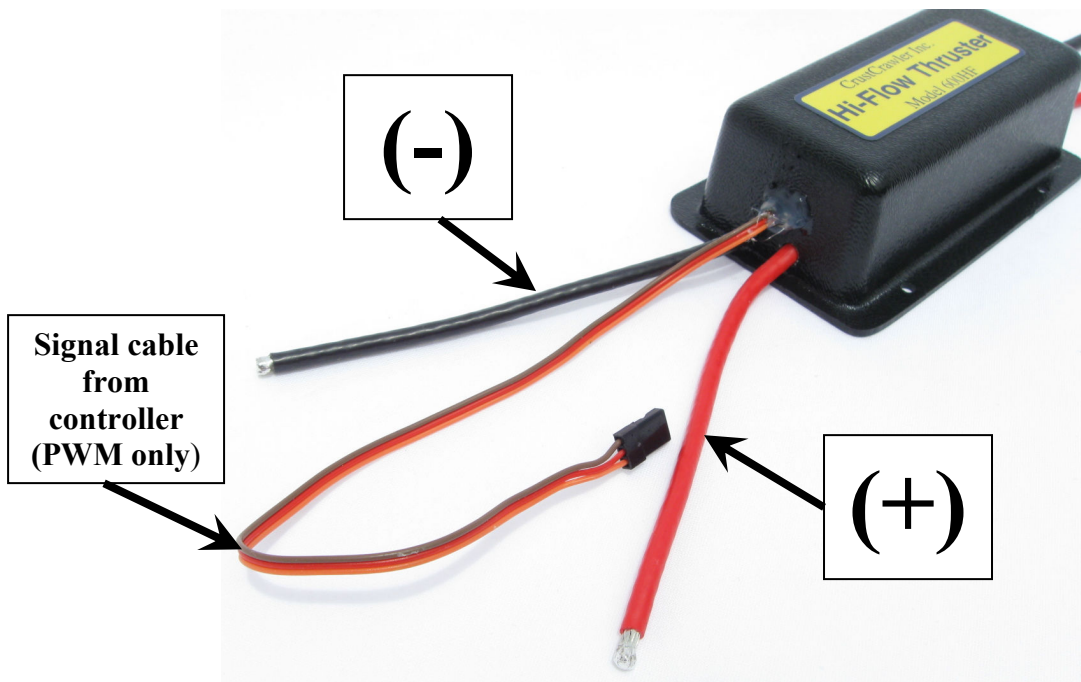

Note: For Phoenix ESC units, the signal cable power requirement is 5volts (Brown and Red wires). The orange wire is for your PWM signal.

Hi-Flow Thruster Connection

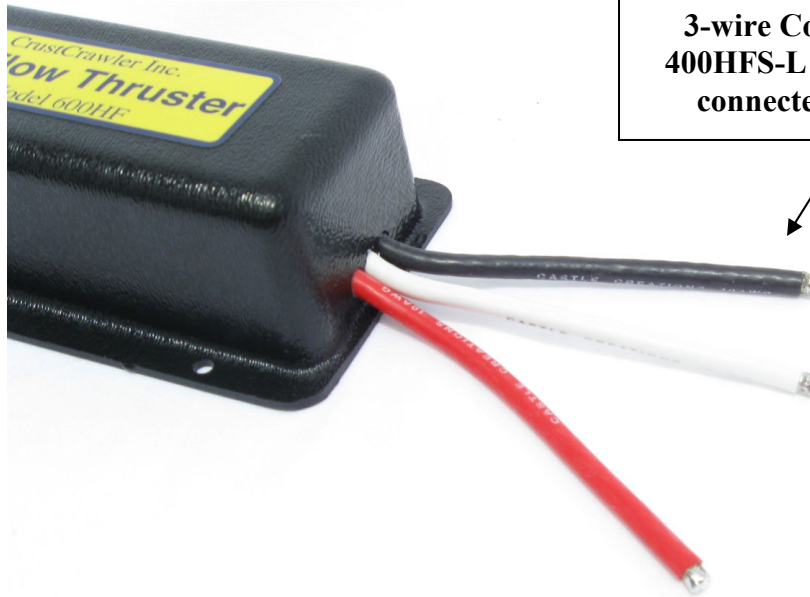

Clockwise Rotation – Right Hand Thrusters

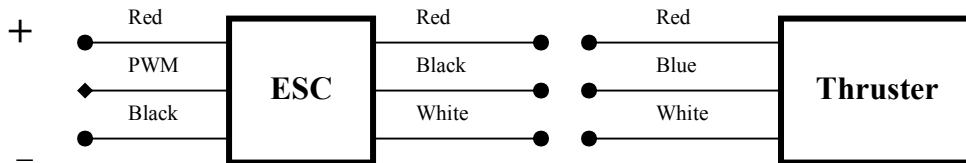

Counter-Clockwise Rotation – Left Hand Thrusters

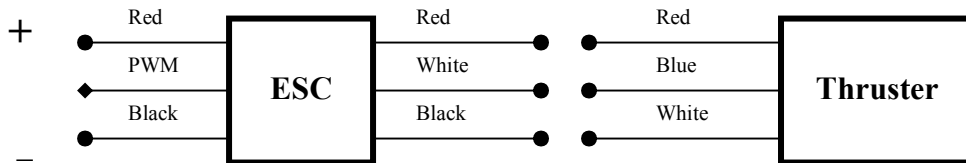

Note: Swapping any (2) of the (3) thruster wires connected to the ESC will reverse the rotation of the propeller.

- **Note:** See page 12 for more information on propeller and correct rotation information

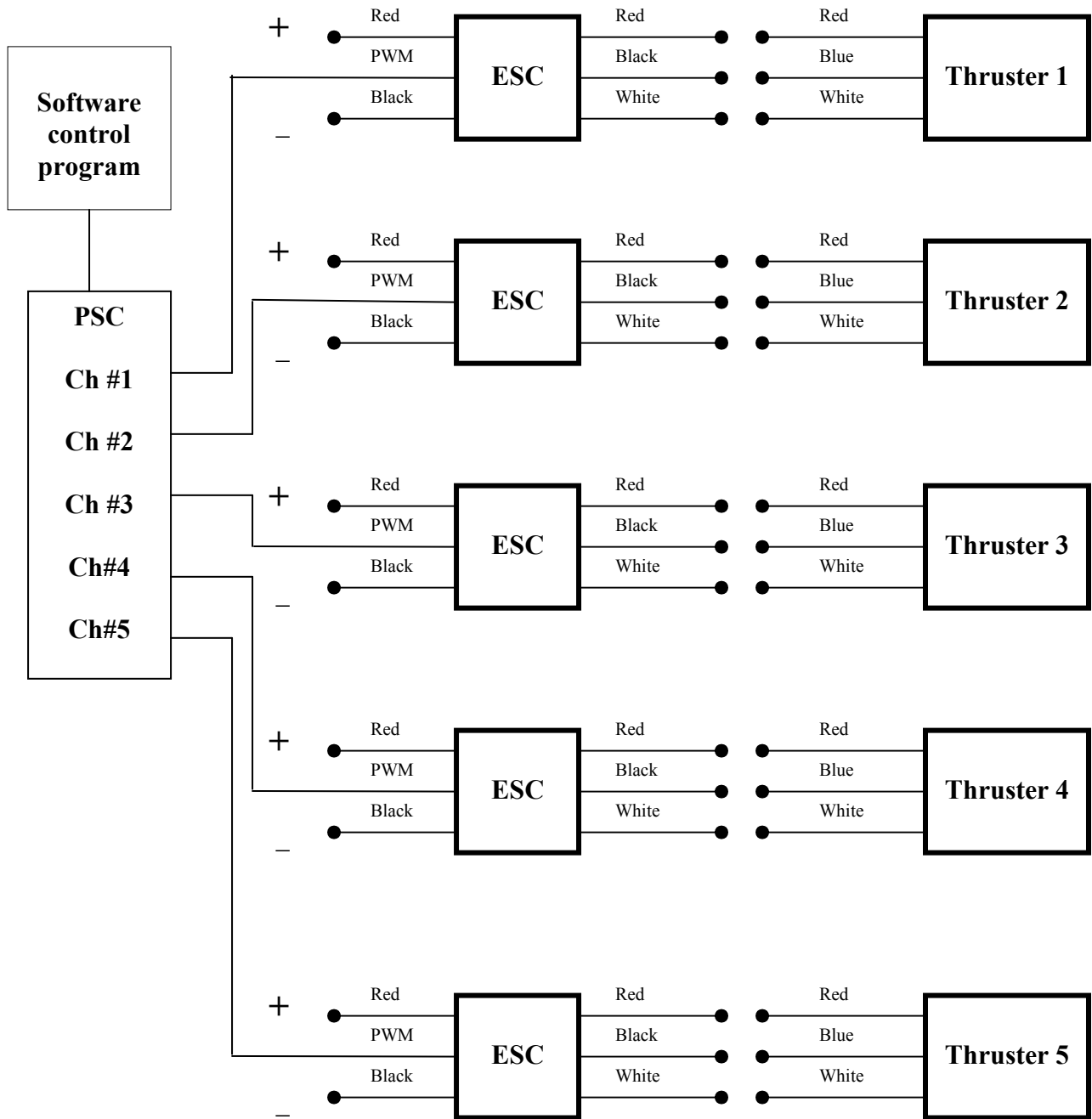

- The diagram above depicts an example of thruster control using a Castle creations Hydra / Phoenix Electronic Speed Controller (ESC) and the Parallax Servo Controller (PSC). This is just one example of many ways of which you can control the 400HFS-L thruster.

Throttle Calibration of the Castle Creations Hydra / Phoenix ESC

When the Castle creations Hydra / Phoenix ESC is first connected to the Hi-Flow 400HFS-L thruster, the Hydra / Phoenix must be calibrated to your throttle. The “throttle” used can take many forms but is not limited to:

- Software Throttles
- Joysticks
- Sliders

Once the Hydra / Phoenix is calibrated to each thruster, there is no need to calibrate the Hydra / Phoenix 120 again unless you have changed to a different type of throttle.

Calibration Steps

The Hydra / Phoenix manual has basic steps on how to calibrate the Hydra / Phoenix to your throttle. We have summarized those steps below. Before proceeding with the steps below, ensure that your Hydra / Phoenix is solidly connected (soldered and insulated) to your 400HFS-L thruster and you have the proper power connections.

Step 1

With power off to your Hydra / Phoenix , move your throttle to full forward throttle

Step 2

Turn on the power to your Hydra / Phoenix . You will hear a series of short “beeps” followed by a steady series of beeps.

Step 3

Once there is a steady series of beeps, move your throttle to full reverse throttle. You will hear a series of short beeps followed by a steady series of beeps.

Step 4

Once there is a steady series of beeps, move your throttle to neutral or center. There will be a series of short beeps followed by silence. Your Hydra / Phoenix ESC is now calibrated to your throttle.

Caution! Always remember to ensure your throttle setting is in the neutral position when powering on your Hydra / Phoenix ESC’s. Failure to do so could result in the thruster running at the current throttle setting or the Hydra / Phoenix going back into calibration mode.

A Note about Throttle Settings and Maximum Power of the Thruster

Whatever throttle you choose to use (computer, joystick etc.) with the 400HFS-L Hi-flow Thruster it is important to note the following:

3. Once you complete the calibration routine of the throttle device you are using with the Hydra / Phoenix ESC's it is important to note that your full throttle settings **DO NOT DIRECTLY** relate to the maximum power rating of the thruster (130W)!
4. In order to determine the maximum physical setting that you can move your throttle to without exceeding the thrust rating of the 400HFS-L thruster of 15 pounds, you will have to monitor either the thrusters thrust rating so that it does not exceed 15 lbs. of thrust and/or ensure it does not exceed about 130W of power at 24volts (as an example)

Note: Refer to the Current / vs. Thrust rating chart on page 5.

- Failure to do so will result in thermal damage to the 400HFS-L thruster motor!

Right Hand / Left Hand Propeller Configurations

The Hi-Flow thrusters come with either a right hand or left hand propeller configuration. Right and left hand propellers are needed whenever (2) Hi-flow thrusters are mounted in a parallel (side by side) configuration from each another. With each propeller rotating in an opposite direction from each other, the opposite rotation will cancel out each thrusters torque resulting in the UROV body traveling in a straight line.

- For all other, single mount Hi-Flow thrusters that are mounted in your UROV, either left or right hand propellers configurations may be used.



**Clockwise Rotation
Hi-Flow Thruster –
Right Hand Propeller**

**Counterclockwise
Rotation
Hi-Flow Thruster –
Left Hand Propeller**

To determine the correct rotation of the propeller:

- If the curve of the propeller is on the **right sides** of the blades (above left) – Clockwise rotation = forward thrust
- If the curve of the propeller is on the **left sides** of the blades (above right) – Counterclockwise rotation = forward thrust

Important! Please Read!

Important Information about the proper operation and care of the Hi-Flow 400HFS-L Thruster

CrustCrawler's Hi-Flow series of thrusters are designed to be a rugged, affordable choice for all types of AUV/ROV applications. To ensure many hours of reliable use, the best practices listed below will ensure a long service, free life of the thruster motor and gearbox.

Operating Best Practices

- NEVER abruptly go from forward to reverse thrust or reverse to forward thrust. This type of operation can lead to gearbox damage.
- Always slowly ramp up and down the thruster speed. NEVER abruptly start and stop the thruster as this can lead to gear box damage!
- NEVER run the thrusters at full throttle (24 or 50 volts) for longer than 10 – 15 seconds at a time. Normal operating parameters for the 400HFS-L is 80% max of full throttle. Failure to do so can lead to gear box damage and or thermal damage to the thruster.
- NEVER attempt to remove the propeller assembly from the motor shaft!! Attempting to remove the prop assembly from the motor shaft can permanently damage other components of the thruster.
- NEVER leave the thruster soaking in water when not in use.
- Always re-grease the grease gallery after every use. Failure to do so can leave water in the grease gallery which can lead to damaged thruster components.
- **Before applying grease to the grease gallery after use, tilt the thruster to 30 – 45 degrees and run for 40 – 60 seconds to ensure most of the water is purged from the grease gallery**
- Never pull on the wires at the back of the thruster or sharply bend them to one side as this may cause thruster water leakage and damage the thruster.

- **Always check to ensure that the propeller nut and propeller set screws are tight before and after every use!** If loose, re-apply Loctite to the set screws and re-install the set screw.
- **NEVER** run the Hi-Flow thruster out of the water at full throttle. Always run the thruster out of the water (for testing etc) at 50% max of full throttle for no longer than 40 -60 seconds at a time., The 400HFS-L is designed to run in the water not out of the water.
- **Never exceed the thrust rating of the thruster of 15 pounds or approximately 130W** (Power = Voltage X Current) Always monitor your current rating vs. your throttle input when setting up and testing your thruster(s). This is especially true for 25 and 50 volt users.
- If your thrusters were used in salt water, always rinse the entire thruster, especially the front of the motor and prop assembly with fresh water after each use and re-grease the grease gallery.
- Ensure that you provide a solid, soldered connection when connecting the ESC to the thruster. Always use shrink tubing and a good sealant compound to ensure that each connection is sealed and waterproof (**“Liquid Tape” is an excellent, fast drying sealant that can be purchased at most hardware stores**).
- **Always ensure that water has been purged from the grease gallery of the thruster after each use and re-greased.**

A Note about Throttle Settings and Maximum Power of the Thruster

Whatever throttle you choose to use (computer, joystick etc.) with the 400HFS-L Hi-flow Thruster it is important to note the following:

5. Once you complete the calibration routine of the throttle device you are using with the Hydra / Phoenix ESC's it is important to note that your full throttle settings **DO NOT DIRECTLY** relate to the maximum power rating of the thruster!
6. In order to determine the maximum physical setting that you can move your throttle to without exceeding the thrust rating of the 400HFS-L thruster of 15 pounds, you will have to monitor either the thrusters thrust rating so that it does not exceed 15 lbs. of thrust and/or ensure it does not exceed about 130W of power at 24volts (as an example)

Note: Refer to the Current / vs. Thrust rating chart on page 5.

- Failure to do so will result in thermal damage to the 400HFS-L thruster motor!

Applying Grease to the Grease Gallery

1. Remove the grease screw as shown in figure 1.
2. Apply the white lithium grease using the supplied grease syringe until excess grease begins to emerge from between the prop adapter and grease gallery fitting.
3. Rotate the propeller 5 complete turns
4. Repeat steps 1 -2
5. Re-install the grease screw

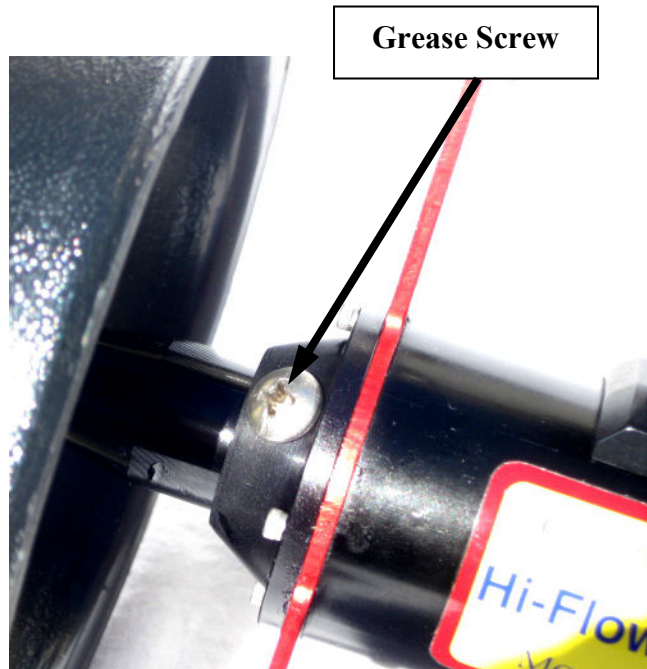

Figure 1 - Remove Grease Screw

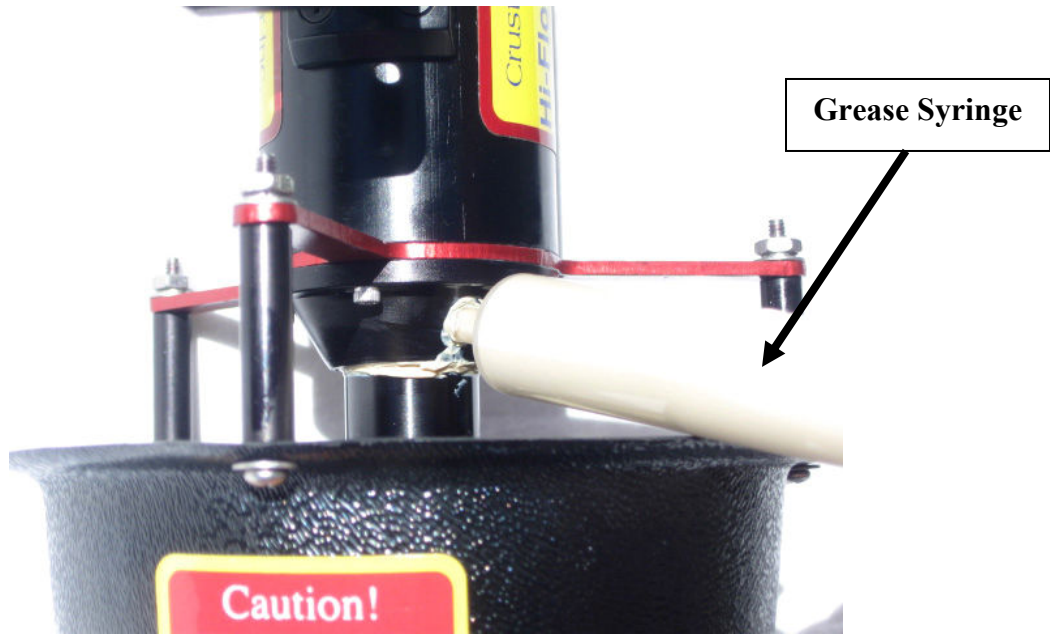

Figure 2 - Apply grease using grease syringe

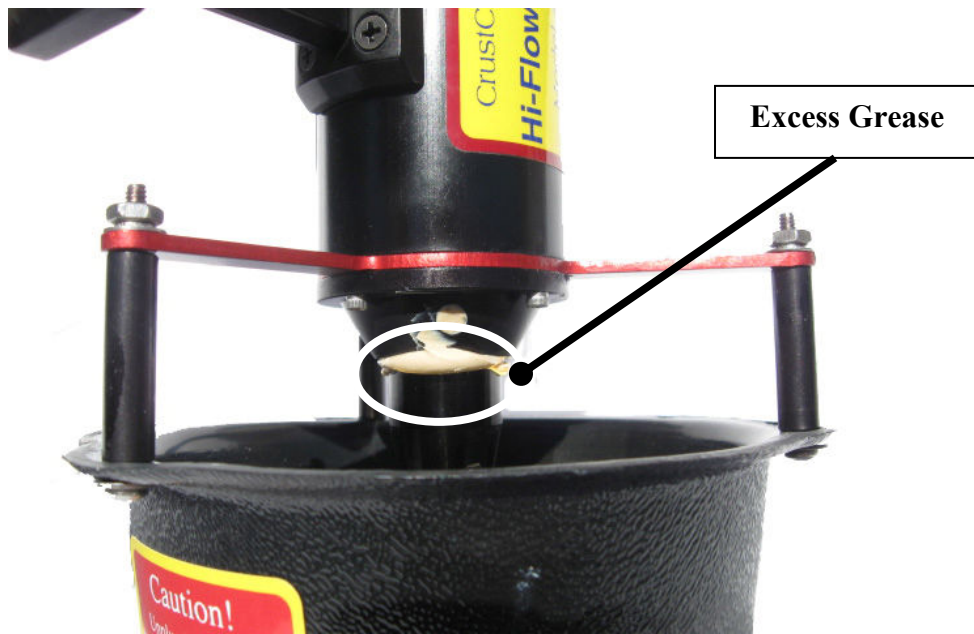

Figure 3 - Apply grease until excess grease emerges

Note: White Lithium grease is supplied to thruster orders of (3) units or more. If you are using your own grease, be sure to clean out the existing grease before applying a different type of marine grease or equivalent to the grease gallery as some grease can react to other grease types.

400HFS-L Thruster Mounting Bracket

(Optional)



- Material – Machined 6061 T6 Aluminum
- Finish – Hard Anodized Black
- Mounting Screws – Quantity (6) - 4/40 (#4) – 1” (2.54cm)
- Thruster Mounting Screws – Quantity (4) - Stainless Steel 4/40 (#4) – 3/8” mounting screws
- Bracket / Kort Nozzle Clearance - .31” (7.8mm)

Mounting Hole Dimensions

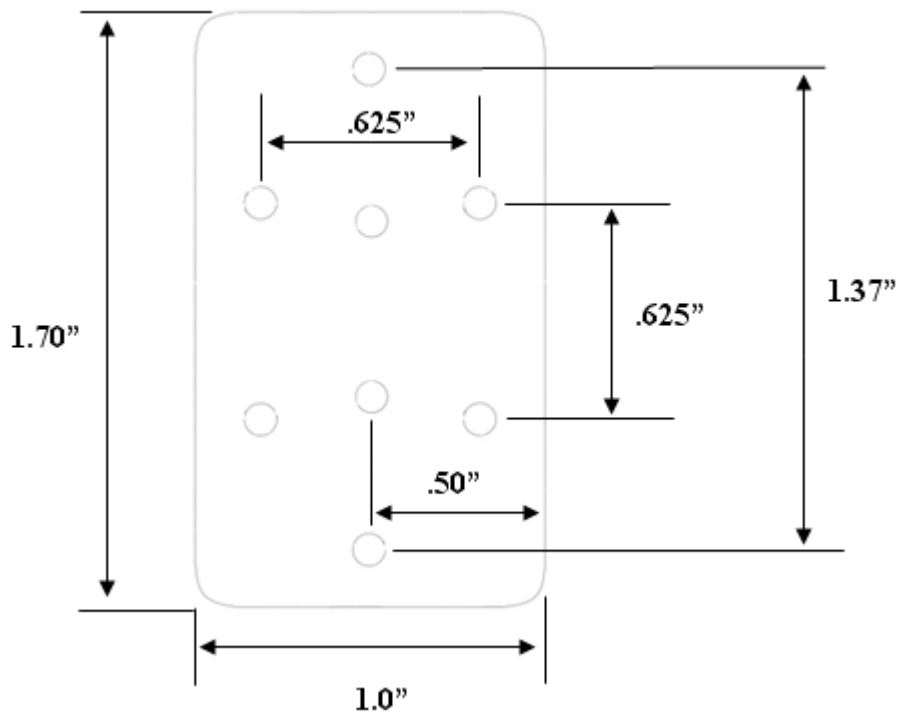



Figure 3 - 400HFS-L Thruster with Mounting Bracket

- Use the supplied stainless steel, #4 (3/8") mounting screws to attach the thruster mounting bracket to the body of the thruster.
- Use a thread-locker type of sealant (like "Loctite or equivalent) for each of the (4) screws when mounting the bracket to the thruster.

Note: The 400HFS-L thruster mounting bracket will only fit 400HFS-L thrusters sold after February 2011. Contact Crustcrawler for hole dimensions for the thrust body if you are going to machine the thruster body to accept the 400HFS-L thruster bracket.

Support

Support, should you need, it is available in 2 ways:

Forums - <http://forum.crustcrawler.com/phpBB3/index.php>

Phone – 480-577-5557

We strongly suggest questions dealing with control software, wiring and other related configuration information be posted on our forums. We use the forums to post code samples, wiring diagrams and pictures to help resolve customer questions quickly and efficiently.

Remember, we can't see your code or wiring over the phone, but we can see it using our forums! Please visit our web site frequently as we will be releasing more software and accessories in the coming months for our line of UROV and ROV products.